

Internal Freewheels FSN

for keyway connection on the outer ring
with rollers

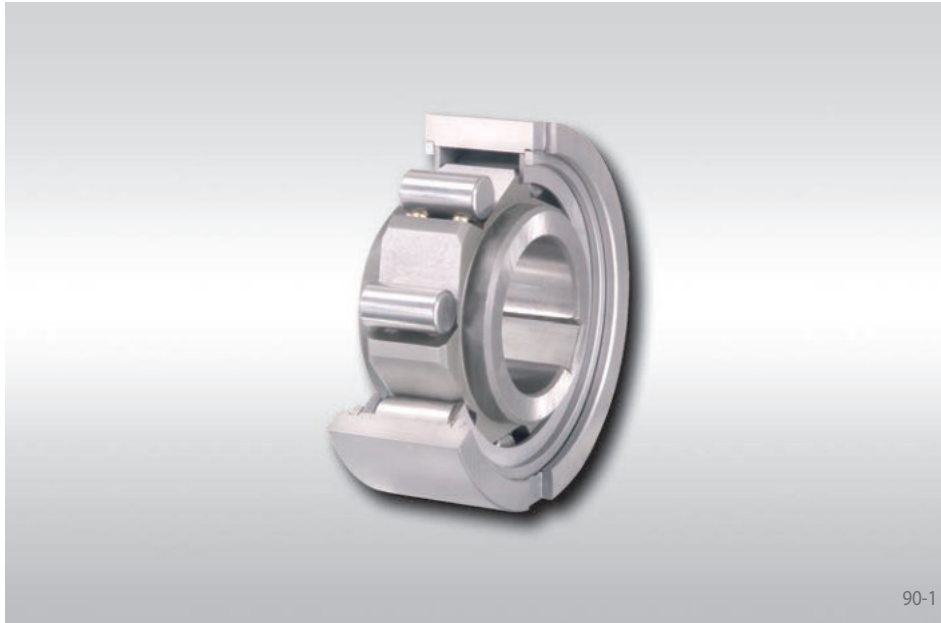

Application as

- ▶ Backstop
- ▶ Overrunning Clutch
- ▶ Indexing Freewheel

Features

Internal Freewheels FSN are roller freewheels without bearing support.

The freewheel is built into the customer housing. This makes compact, space-saving fitting solutions possible.

Nominal torques up to 3 000 Nm. The faces of both sides of the outer ring are provided with grooves for torque transmission.

Bores up to 80 mm.

Application example

Internal freewheel FSN 50 as backstop fitted to the end of the intermediate shaft of a spur gearbox in the drive of an elevator. In the case of a motor stop, the elevator must be held securely so that the conveyor goods do not pull backwards.

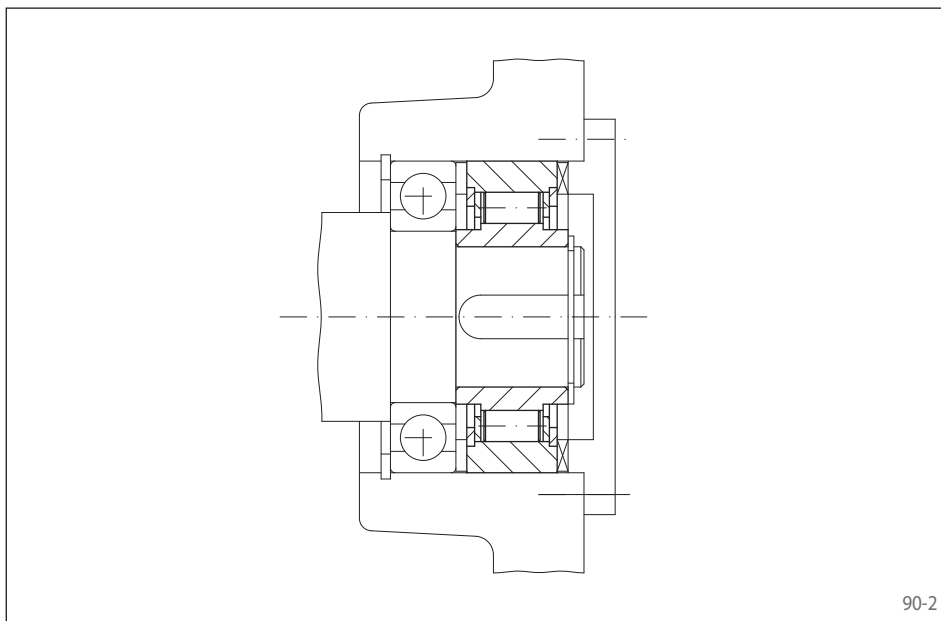

Internal Freewheels FSN

for keyway connection on the outer ring
with rollers

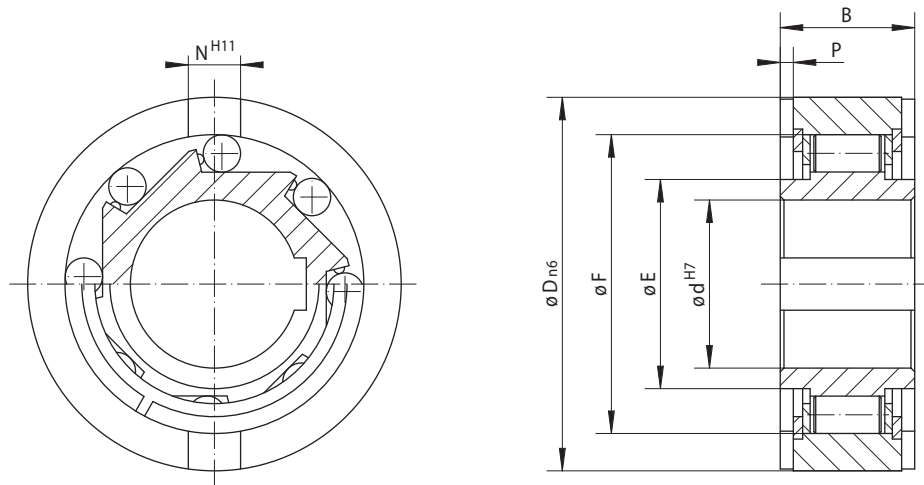

91-1

91-2

Indexing Freewheel Overrunning Clutch Backstop	Standard type For universal use	Dimensions

Freewheel Size	Nominal torque M_N Nm	Max. speed		Bore d mm	B mm	D mm	E mm	F mm	N mm	P mm	Weight kg
		Inner ring freewheels/ overruns min^{-1}	Outer ring freewheels/ overruns min^{-1}								
FSN 8	11	3050	4700	8	13	35	18,5	28	4	1,3	0,1
FSN 12	11	3050	4700	12	13	35	18,5	28	4	1,3	0,1
FSN 15	36	2350	3700	15*	18	42	21,0	36	5	1,7	0,1
FSN 17	56	2100	3300	17*	19	47	24,0	40	5	2,0	0,2
FSN 20	90	1750	3200	20*	21	52	29,0	45	6	1,5	0,2
FSN 25	125	1650	3100	25*	24	62	35,0	52	8	2,0	0,4
FSN 30	210	1400	2200	30*	27	72	40,0	60	10	2,5	0,6
FSN 35	306	1250	2150	35*	31	80	47,0	68	12	3,5	0,8
FSN 40	430	1100	2050	40*	33	90	55,0	78	12	3,5	0,9
FSN 45	680	1000	1900	45*	36	100	56,0	85	14	3,5	1,3
FSN 50	910	900	1750	50*	40	110	60,0	92	14	4,5	1,7
FSN 60	1200	750	1450	60*	46	130	75,0	110	18	5,5	2,8
FSN 70	2000	600	1000	70*	51	150	85,0	125	20	6,5	4,2
FSN 80	3000	500	900	80*	58	170	95,0	140	20	7,5	6,0

■ Freewheels with bore diameters highlighted blue in the table are available with short delivery times.

The maximum transmissible torque is 2 times the specified nominal torque. See page 14 for determination of selection torque.

Keyway according to DIN 6885, page 1 • Tolerance of keyway width JS10.

* Keyway according to DIN 6885, page 3 • Tolerance of keyway width JS10.

Mounting

Internal Freewheels FSN are without bearing support. Concentric alignment of inner and outer ring must be provided by the customer.

The tolerance of the housing bore D must be ISO H7 or G7 and the tolerance of the shaft must be ISO h6 or j6.

The outer ring has to be completely enclosed in a stable housing to transmit the listed torques.

Lubrication

An oil lubrication of the specified quality must be provided.

Example for ordering

Freewheel size FSN 12, standard type:

- FSN 12

Morskate®



Any questions? Please contact us.

Morskate Aandrijvingen BV

Oosterveldsingel 47A
7558 PJ Hengelo (Ov)
The Netherlands

NL

T +31 (0)74 - 760 11 11
info@morskateaandrijvingen.nl
www.morskateaandrijvingen.nl

DE

T +49 692 - 222 34 95
info@morskateantriebstechnik.de
www.morskateantriebstechnik.de

EN

T +31 (0)74 - 760 11 11
info@morskatedrivetechnology.com
www.morskatedrivetechnology.com